

Ignition transformers TZI, TGI

TECHNICAL INFORMATION

- Electrical ignition of gas burners
- Ignition and burner control with a single electrode possible



Contents

Contents	2
1 Application	3
1.1 Double-electrode operation	5
1.2 Single-electrode operation	5
2 Certification	6
2.1 Certificate download	6
2.2 EU certified	6
2.3 UL recognized	6
2.4 Eurasian Customs Union	6
3 Connection diagrams	7
4 Replacement possibilities	8
5 Selection	9
6 Project planning information	10
6.1 Operation	10
6.2 Installation	10
6.3 Cable selection	10
6.3.1 Ignition cable	10
6.3.2 Functional equipotential bond	11
6.4 Reduction of EMC, wiring	12
6.5 Single-electrode operation	12
6.6 Intermittent operation/Star electrodes	12
6.7 Duty cycle	13
7 Accessories	14
7.1 High-voltage cable	14
7.2 Radio interference suppressed terminal boots	14
8 Technical data	15
8.1 Dimensions	17
9 Legend	19
For more information	20

1 Application



TZI



TGI

Ignition transformers TZI and TGI are designed for high-voltage spark ignition of gas burners with a single-pole output to protective earth. The ignition transformers can also be used on burners with single-electrode operation; the ignition current and ionization current flow over a common electrode. The ignition transformer TZI must be mounted

in a non-contact housing, for example in a control cabinet. It fulfils the requirements for enclosure IP 00. Ignition transformer TGI in its die-cast aluminium housing meets the requirements for enclosure IP 65, NEMA 4. It is suitable for on-site mounting near the burner.

1 Application



Bogie hearth forging furnace in the metallurgical industry



Walking beam furnace with overhead firing



Intermittent shuttle kiln in the ceramics industry

1.1 Double-electrode operation

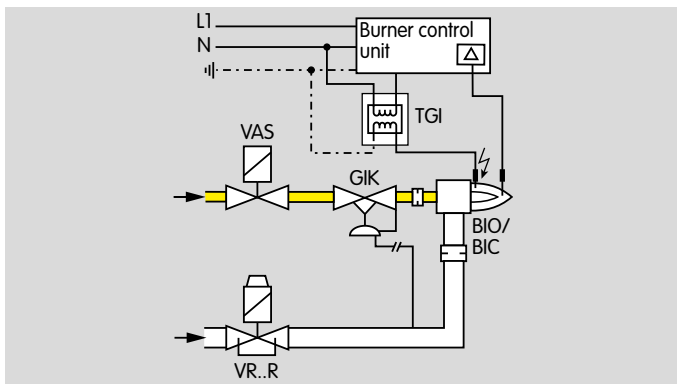

Ignition using spark electrode

Ignition transformer TGI is supplied with voltage via the automatic burner control unit IFD 258. The ignition transformer generates a high voltage. This high voltage creates ignition sparks between the spark electrode and burner ground. After the burner start, a current flows via the flame rod for flame control.

1.2 Single-electrode operation

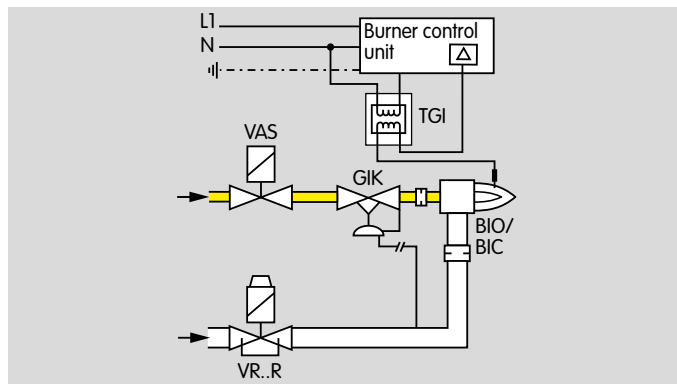

Ignition using a spark electrode and flame rod.

After burner start, a flame control current flows via the same electrode that is also used for ignition.

2 Certification

2.1 Certificate download

Certificates – see www.docuthek.com

2.2 EU certified

TZI..E and TGI..E only.



- 2014/35/EU (LVD), Low Voltage Directive
- 2014/30/EU (EMC), Electromagnetic Compatibility Directive
- 2011/65/EU – RoHS II
- 2015/863/EU – RoHS III
- EN 61558-2-3:2011-04
- Conformity with EN 61000-6-2:2005/AC:2005 and EN 61000-6-4:2007/A1:2011 must be checked by the system operator in the specific application in which the transformers are to be used.

2.3 UL recognized

TZI..T only: USA and Canada.



For USA: Product Category XPZZ2, File No. E529373,
for Canada: Product Category XPZZ8, File No. E529373.
www.ul.com

2.4 Eurasian Customs Union



The products TZI, TGI meet the technical specifications of the Eurasian Customs Union.

3 Connection diagrams

Explanation of symbols, see page 19 (9 Legend)

Double-electrode operation

TZI

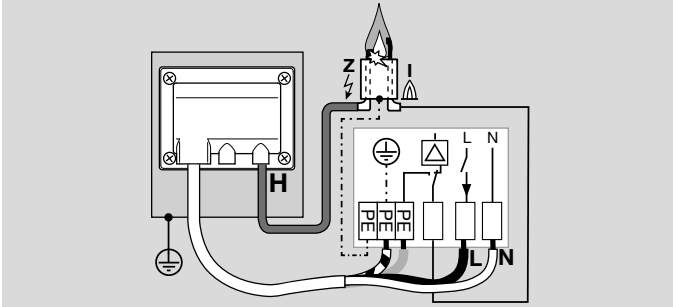

TGI

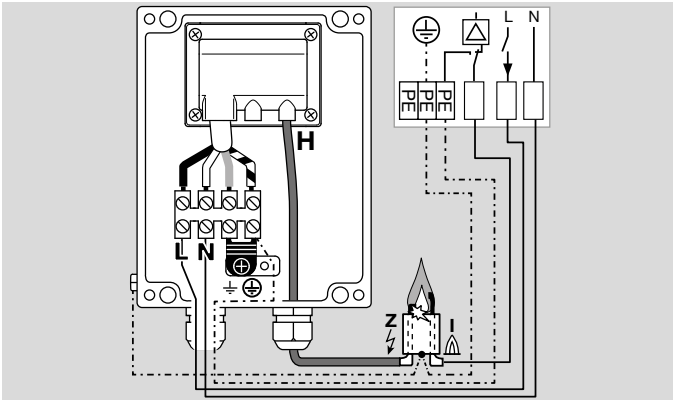

Single-electrode operation

Single-electrode operation is possible only in conjunction with suitable burner control units.

For single-electrode operation, wire a conductor for the functional equipotential bond between the burner and the burner control unit.

TZI

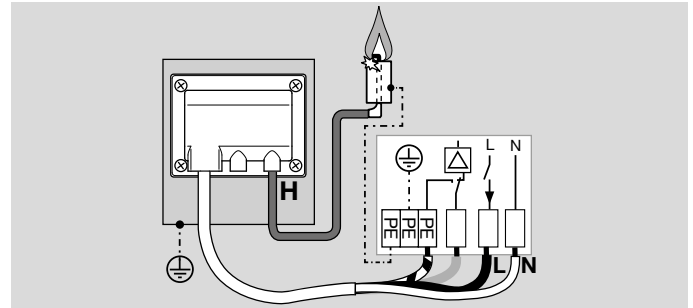

TGI

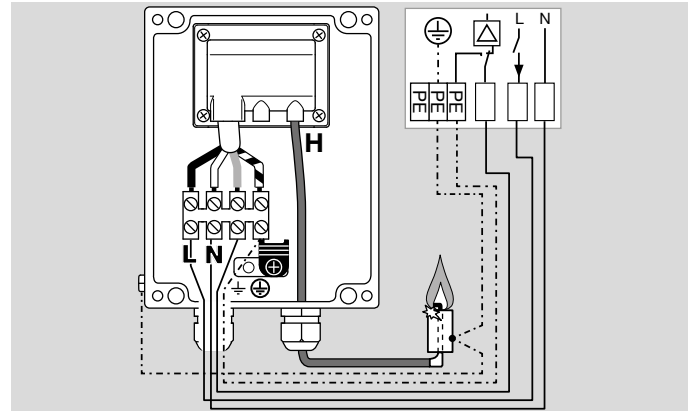

4 Replacement possibilities

TZI

Old TZI		New TZI	
Type	Order No.	Type	Order No.
TZI 5-15/100R	84331382	TZI 5-15/100QE TZI 5-15/100QT	84391110 84391111
TZI 5-15/100W	84331381	TZI 5-15/100WE	84391150
TZI 7-25/20R	84335123	TZI 8-20/19QE TZI 8-20/19QT	84391120 84391121
TZI 7-25/20W	84327455	TZI 8-20/19WE	84391160
TZI 7,5-12/100R	84331384	TZI 8-12/100QE TZI 8-12/100QT	84391130 84391131
TZI 7,5-12/100W	84331383	TZI 8-12/100WE	84391170
TZI 7,5-20/33R	84329111	TZI 8-20/33QE TZI 8-20/33QT	84391140 84391141
TZI 7,5-20/33W	84326116	TZI 8-20/33WE	84391180

TGI

Old TGI		New TGI	
Type	Order No.	Type	Order No.
TGI 5-15/100R	84391075	TGI 5-15/100QE TGI 5-15/100QT	84391210 84391211
TGI 5-15/100W	84391065	TGI 5-15/100WE	84391250
TGI 7-25/20R	84391090	TGI 8-20/19QE TGI 8-20/19QT	84391220 84391221
TGI 7-25/20W	84391080	TGI 8-20/19WE	84391260
TGI 7,5-12/100R	84391055	TGI 8-12/100QE TGI 8-12/100QT	84391230 84391231
TGI 7,5-12/100W	84391045	TGI 8-12/100WE	84391270
TGI 7,5-20/33R	84391030	TGI 8-20/33QE TGI 8-20/33QT	84391240 84391241
TGI 7,5-20/33W	84391020	TGI 8-20/33WE	84391280

5 Selection

Ignition transformers TZI and enclosed ignition transformers TGI can be supplied for mains voltages of 120 V or 230 V.

TZI	Ignition transformer
TGI	Ignition transformer, enclosed
5	5 kV high voltage
8	8 kV high voltage
-12	Output current: 12 mA at 50 Hz (9 mA at 60 Hz)
-15	Output current: 15 mA at 50 Hz (10–11 mA at 60 Hz)
-20	Output current: 20 mA at 50 Hz (16 mA at 60 Hz)
/19	19% duty cycle
/33	33% duty cycle
/100	100% duty cycle
Q	Mains voltage: 120 V AC
W	Mains voltage: 230 V AC
E	CE approved
T	UL listed, CSA approved

6 Project planning information

6.1 Operation

The ignition transformers are suitable only for applications for igniting gas burners and gas-ignited or directly ignited oil burners. A burner control unit with an integral fuse to suit the current consumption of the ignition transformer must be installed for activation. Do not operate the transformers when no ignition sparks are created (distance between spark electrode and burner ground = 2 ± 0.5 mm). The duty cycle and the ambient temperature must not exceed the permitted limits.

6.2 Installation

Vertical, with connections at the bottom or horizontal (TZI: standing on attachment brackets, TGI: lying flat), with connections to the side. Position the ignition transformer right next to the burner (recommended ignition cable length: max. 5 m, recommended < 1 m).

TZI

The length of the mains cable is approx. 410 mm.

Install in external housing or control cabinet with enclosure \geq IP 54. Ensure that a warning sign with the wording "Warning: electricity" to DIN EN ISO 7010 in permanently legible condition is placed on the external housing or control cabinet.

6.3 Cable selection

Use a mains cable suitable for the type of operation (max. 1.5 mm^2 (AWG 16), single core or fine-strand with wire-end ferrules) and complying with local regulations.

Use a conductor for a functional equipotential bond (4 mm^2 , compliant with local regulations) between the burner and the ignition transformer.

TGI

Use a cable lug or eyelet to secure the conductor for the functional equipotential bond to the housing of the TGI.

The housing of the TGI has two M20 cable glands with a double seal insert for two cables each with a diameter of up to 7 mm.

6.3.1 Ignition cable

For the ignition cable, use a high-voltage cable, see page 14 (7.1 High-voltage cable). The ignition capacity is lower when using a screened ignition cable.

Ignition cable length:

Recommended < 1 m, max. 5 m. The longer the ignition cable, the lower the ignition capacity.

Use radio interference suppressed terminal boots only on the burner (with $1 \text{ k}\Omega$ resistor), see page 14 (7.2 Radio interference suppressed terminal boots).

6.3.2 Functional equipotential bond

The objective of a functional equipotential bond is to reduce the effects of an insulation defect and electrical interference on sensitive electrical equipment which could affect the way in which the machine operates. Normally, a functional equipotential bond is achieved by means of a connection to the PE system.

If the level of electrical interference affecting the PE system is not low enough to enable the electrical equipment to function correctly, it may be necessary to connect the functional equipotential bond to a separate grounding conductor for functional grounding, see also IEC 60204-1.

6.4 Reduction of EMC, wiring

External electrical interference must be avoided.

Lay cables individually and, if possible, not in a metal conduit.

Do not lay UV/ionization cable and ignition cable together and lay them as far apart as possible.

Screw the ignition cable securely into the high-voltage connection **H** on the ignition transformer and run to the burner by the shortest possible route.

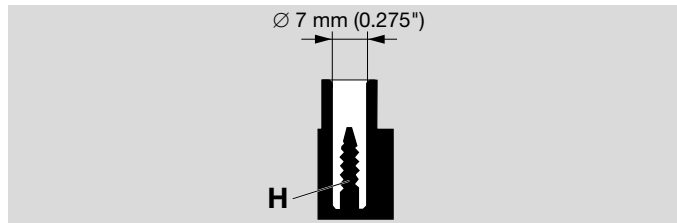

Use radio interference suppressed terminal boots only on the burner (with 1 k Ω resistor), see page 14 (7.2 Radio interference suppressed terminal boots).

EMC depends on the cable length, cable type, cable routing, spark electrode, electrode distance and furnace design. Check the application/system on site to ensure it complies with EMC, for example to EN 61000-6-2:2005/AC:2005 and EN 61000-6-4:2007/A1:2011.

6.5 Single-electrode operation

Single-electrode operation is possible only in conjunction with suitable burner control units.

For single-electrode operation, wire a conductor for the functional equipotential bond between the burner and the burner control unit.

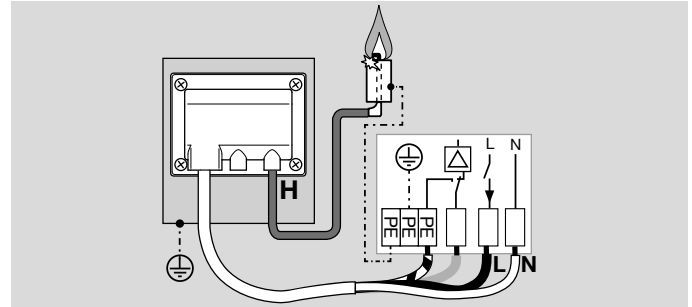

Ensure that the wiring has been done correctly, otherwise the connected units will be damaged.

6.6 Intermittent operation/Star electrodes

We recommend using 8 kV ignition transformers for On/Off intermittent operation or when using burners with star electrodes.

6.7 Duty cycle

The duty cycle indicates for how long the ignition transformer can be switched on within 180 s, without it being overloaded.

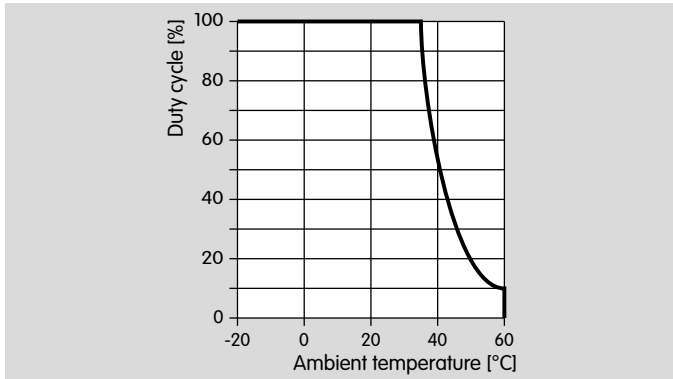

For ignition transformers, the duty cycle is dependent on the ambient temperature.

TZI/TGI duty cycle in %, see page 15 (8 Technical data).

Converting the duty cycle into seconds:

$$\text{Duty cycle [s]} = \frac{\text{Duty cycle [\%]} \times 180 \text{ s}}{100\%}$$

Example

Ignition transformer TZI 8-20/33W with a duty cycle of 33% for an ambient temperature of -20 to +35°C.

$$\text{Duty cycle} = \frac{33 [\%] \times 180 \text{ s}}{100\%} = 59.4 \text{ s}$$

In an ambient temperature of -20 to +35°C, this results in a maximum duty cycle of 59.4 s within 180 s for the ignition transformer.

For an automatic burner control unit with an ignition time $t_z = 1.9 \text{ s}$, for example, the resultant timing cycle is a maximum of 10 ignitions per minute.



For an ambient temperature of 60°C, the timing cycle is reduced to 1 ignition per minute.

7 Accessories

7.1 High-voltage cable

FZLSi 1/7 -50°C (-58°F) to +180°C (+356°F),

Order No. 04250410,

FZLK 1/7 -5°C (23°F) to +80°C (+176°F),

Order No. 04250409.

7.2 Radio interference suppressed terminal boots

Right-angle terminal boot, 4 mm (0.16 inch), interference-suppressed,

Order No. 04115308.

Straight terminal boot, 4 mm (0.16 inch), interference-suppressed,

Order No. 04115307.

Straight terminal boot, 6 mm (0.2 inch), interference-suppressed,

Order No. 04115306.

8 Technical data

Mains voltage:

TZI..Q, TGI..Q: 120 V AC, 50/60 Hz,

TZI..W, TGI..W: 230 V AC, 50/60 Hz.

Output voltage:

TZI 5, TGI 5: 5 kV,

TZI 8, TGI 8: 8 kV.

Electrode distance: 2 ± 0.5 mm.

Length of ignition cable: < 1 m (3.28 ft), max. 5 m (16.4 ft).

Enclosure:

TZI: IP 00,

TGI: IP 65, NEMA 4.

Ambient temperature: -20 to +60°C.

TZI, TGI: silicone-free.

Weight:

TZI../19: 1.4 kg,

TZI../33, TGI../100: 2.0 kg,

TGI../19: 2.5 kg,

TGI../33, TGI../100: 3.1 kg.

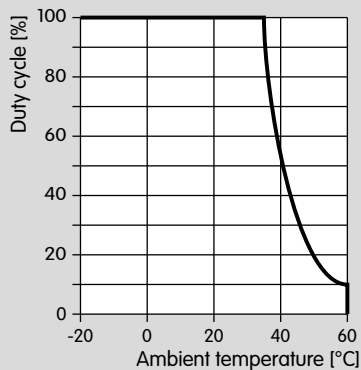

TZI

Type	Input		Output		Duty cycle ²⁾
	A ¹⁾		mA ¹⁾		%
TZI 5-15/100QE	0.9	(0.6)	15	(11)	100
TZI 5-15/100QT	0.9	(0.6)	15	(11)	100
TZI 5-15/100WE	0.4	(0.3)	15	(10)	100
TZI 8-20/19QE	1.9	(1.4)	20	(16)	19
TZI 8-20/19QT	1.9	(1.4)	20	(16)	19
TZI 8-20/19WE	1.0	(0.7)	20	(16)	19
TZI 8-12/100QE	1.2	(0.9)	12	(9)	100
TZI 8-12/100QT	1.2	(0.9)	12	(9)	100
TZI 8-12/100WE	0.6	(0.4)	12	(9)	100
TZI 8-20/33QE	1.7	(1.3)	20	(16)	33
TZI 8-20/33QT	1.7	(1.3)	20	(16)	33
TZI 8-20/33WE	1.0	(0.7)	20	(16)	33

TGI

Type ³⁾	Input		Output		Duty cycle ²⁾
	A ¹⁾		mA ¹⁾		%
TGI 5-15/100QE	0.9	(0.6)	15	(11)	100
TGI 5-15/100QT	0.9	(0.6)	15	(11)	100
TGI 5-15/100WE	0.4	(0.3)	15	(10)	100
TGI 8-20/19QE	1.9	(1.4)	20	(16)	19
TGI 8-20/19QT	1.9	(1.4)	20	(16)	19
TGI 8-20/19WE	1.0	(0.7)	20	(16)	19
TGI 8-12/100QE	1.2	(0.9)	12	(9)	100
TGI 8-12/100QT	1.2	(0.9)	12	(9)	100
TGI 8-12/100WE	0.6	(0.4)	12	(9)	100
TGI 8-20/33QE	1.7	(1.3)	20	(16)	33
TGI 8-20/33QT	1.7	(1.3)	20	(16)	33
TGI 8-20/33WE	1.0	(0.7)	20	(16)	33

1) Values in brackets apply to 60 Hz.

2) Within 3 minutes at -20 to +35°C.

3) Cores of the connection cable: TZI/TGI..E = black, blue, brown, green-yellow; TZI/TGI..T = black, white, red, green.

8.1 Dimensions

TZI

Length of connection cable: approx. 410 mm

TZI../33, TZI../100

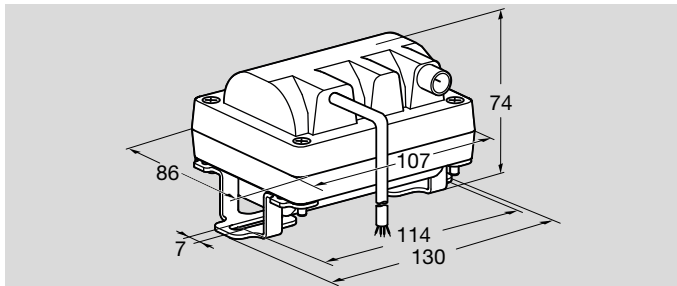

Type	Order No.
TZI 5-15/100QE	84391110
TZI 5-15/100QT	84391111
TZI 5-15/100WE	84391150
TZI 8-12/100QE	84391130
TZI 8-12/100QT	84391131
TZI 8-12/100WE	84391170
TZI 8-20/33QE	84391140
TZI 8-20/33QT	84391141
TZI 8-20/33WE	84391180

TZI../19

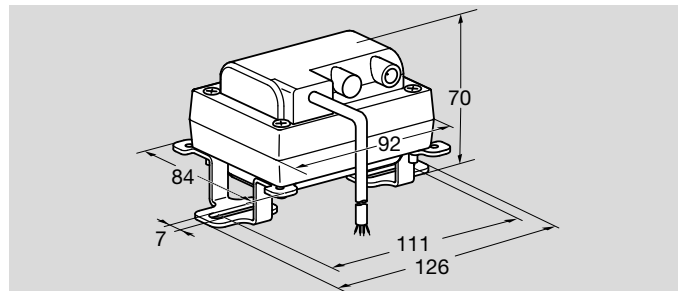





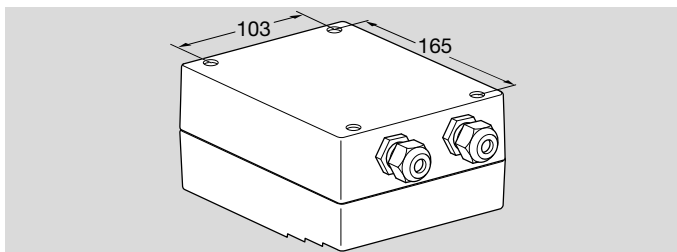
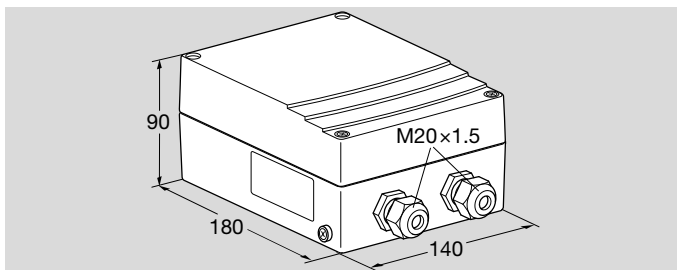



Type	Order No.
TZI 8-20/19QE	84391120
TZI 8-20/19QT	84391121
TZI 8-20/19WE	84391160

TGI



Type	Order No.
TGI 5-15/100QE	84391210
TGI 5-15/100QT	84391211
TGI 5-15/100WE	84391250
TGI 8-20/19QE	84391220
TGI 8-20/19QT	84391221
TGI 8-20/19WE	84391260
TGI 8-12/100QE	84391230
TGI 8-12/100QT	84391231
TGI 8-12/100WE	84391270
TGI 8-20/33QE	84391240
TGI 8-20/33QT	84391241
TGI 8-20/33WE	84391280

9 Legend

H	High-voltage connection	
	PE wire connection	
	Burner ground connection	
	Flame control	
	Burner control unit	
	TZI/TGI..E	TZI/TGI..T
	L = black core	L = black core
	N = blue core	N = white core
	Brown core	Red core
	PE = green/yellow core	PE = green core

For more information

The Honeywell Thermal Solutions family of products includes Honeywell Combustion Safety, Eclipse, Exothermics, Hauck, Kromschroder and Maxon. To learn more about our products, visit ThermalSolutions.honeywell.com or contact your Honeywell Sales Engineer.

Elster GmbH
Strotheweg 1, D-49504 Lotte
T +49 541 1214-0
hts.lotte@honeywell.com
www.kromschroeder.com

© 2022 Elster GmbH

We reserve the right to make technical modifications in the interests of progress.

